

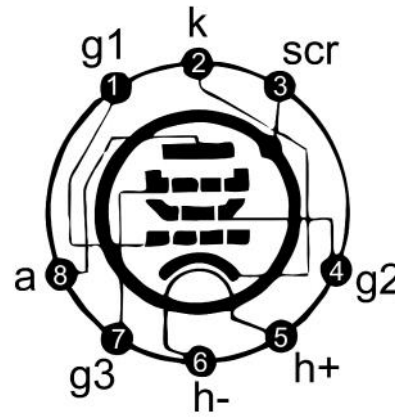

TYPE: **VF14M**  
Y8A OCTAL  
AUDIO PENTODE

The Phædrus Audio VF14M is suitable for direct replacement of the VF14 (VF14M) tube in Neumann U47 and U48 microphones and other derivative microphones originally specifying this device. See technical specification below. For more information and enquiries, email [sales@phaedrus-audio.com](mailto:sales@phaedrus-audio.com).

The Phædrus Audio VF14M is designed as a drop in replacement (Note 1) for the original Telefunken tube. No modifications to the microphone are necessary.



Viewed from below

## VF14M Electronic Tube™ Technical Specifications

### Recommended operating conditions

**Heater voltage:** Underrun at 35V: fed by 1800Ω resistor from HT (*Note 1.*)

**Heater current:** 40mA

**HT Supply:** 90V (nominal top of R5)

**Anode load:** 100k

**Anode volts:** approx. 35V

**Grid voltage:** 0V

**Grid resistor:** 60 - 100MΩ

**Cathode circuit:** approx. 1V (derived across R3)

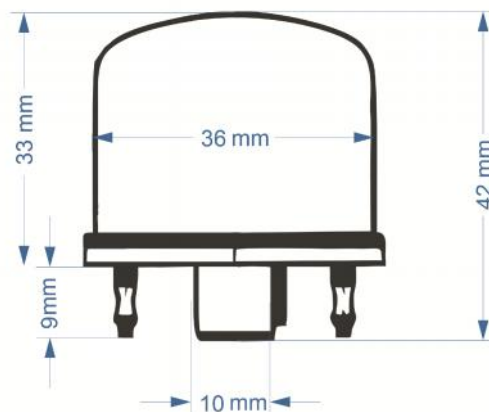

### Notes:

1. i.e. Polarity must be respected. Thus terminal h+ must be positive with respect to terminal h- .





TYPE: VF14M

---

## Warranty and service

If you experience a problem with a Phaedrus Audio product, contact [support@phaedrus-audio.com](mailto:support@phaedrus-audio.com). We will diagnose the problem remotely and advise you of the warranty status. If a repair or replacement is required, we will issue a Return Merchandise Authorization (RMA) number and tell you where to send the unit to be repaired. You MUST have an RMA number before you return the equipment to Phaedrus Audio's support service. Phaedrus Audio will not accept responsibility for loss or damage in shipping or for equipment returned without valid paperwork and/or a valid RMA number. Remember, warranty is void if product serial numbers have been removed or altered, or if the product has been damaged by abuse, accident or unauthorized modification and/or repair. There are no user serviceable parts inside.

PLEASE RETAIN YOUR SALES INVOICE. IT IS YOUR PROOF OF PURCHASE COVERING YOUR LIMITED WARRANTY. LIMITED WARRANTY IS VOID WITHOUT SUCH PROOF OF PURCHASE.

### Phaedrus Audio's Limited Warranty

This limited warranty is valid only if you purchased the product from Phaedrus Audio or from a Phaedrus Audio authorized dealer in the country of purchase. Phaedrus Audio warrants that the equipment it manufactures shall be free from defects in material and workmanship for a period of one year from the original date of purchase; unless a longer minimum warranty period is mandated by applicable local laws. If equipment fails due to such defects within this period, Phaedrus Audio will, at its option, repair or provide a replacement for the defective product. This warranty does not extend to any Phaedrus Audio product that has been damaged or rendered defective as a result of: accident, misuse, or abuse; or by the use of parts not manufactured or supplied by Phaedrus Audio; or by unauthorized modification or attempted repair to the product; or by acts of God/Nature (accident, fire, flood, etc.) or any other condition that is beyond the control of Phaedrus Audio. As this product does not "age" with time, this warranty does not cover "changes in sound", but is limited to failure to pass signal during the warranty period. This limited warranty is invalid if the factory applied serial number has been altered or removed from the product.

This limited warranty is extended exclusively to the original buyer (customer of Phaedrus Audio, or authorized retail dealer) and is not transferable to anyone who may subsequently purchase the product. No other person or organisation shall be entitled to give any warranty promise on behalf of Phaedrus Audio.

Phaedrus Audio makes no other warranties, expressed or implied, of merchantability, fitness for a particular purpose or otherwise.

Phaedrus Audio's liability is limited to repair or replacement by Phaedrus Audio, at its sole discretion and, in no event, will Phaedrus Audio be liable for any direct, indirect, special, incremental or consequential damages resulting from any defect in the product, including lost profits, damage to property and, to the extent permitted by law, damage for personal injury, even if Phaedrus Audio has been advised of the possibilities of such damages.

For any hardware defects experienced by the customer while the product is under warranty, Phaedrus Audio will incur the shipping cost to the customer and the customer is responsible for the shipping costs to Phaedrus Audio designated after sales service office.

**Warranty service conditions are subject to change without notice. For the latest warranty terms and conditions and additional information regarding Phaedrus Audio's limited warranty, please see complete details online at [www.phaedrus-audio.com](http://www.phaedrus-audio.com).**

